

FOR SERVICE REFERENCE ONLY

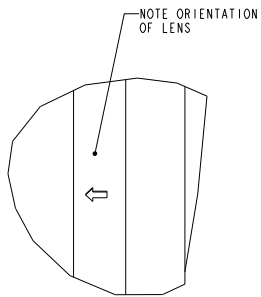

DETAIL A  
SCALE 8.000

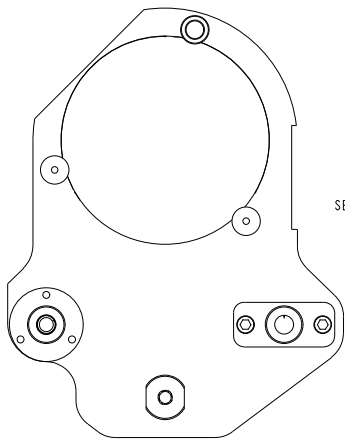
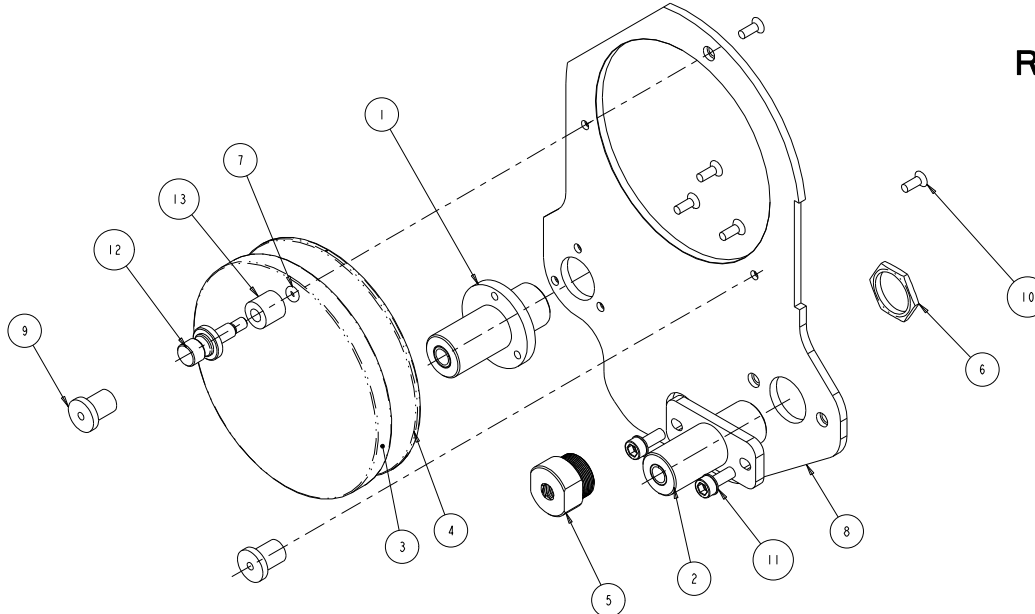

SCALE 1.000

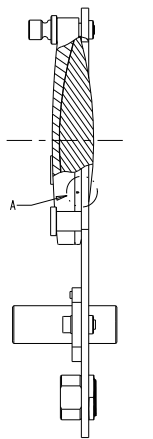

SECTION A-A

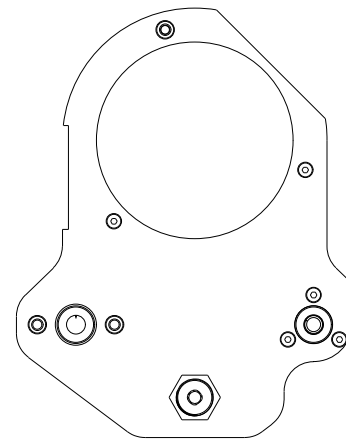

13	1	TW548	90717054	TUBING, SILICONE 50 DUR BLK .188 ID
12	1	TW366	90705032	THUMBSCREW, LENS, ACHROMAT
11	2	SCREWM4AC10W-BZ	91000410	SCREW, M4 SOCKET CAP 10 BZ SEMS
10	5	SCREWM3AF08BZ	91040308	SCREW, M3 SOCKET CSNK FLAT 08 BZ W/PATCH
9	2	TW320	90701377	RETAINER, LENS, ZOOM
8	1	TW661	99080314	PLATE, ACHROMAT MOUNT
7	1	O-RING	90701373	O-RING, 5/32 ID X 9/32 OD, VITON
6	1	NUTS8-24LPS	90703053	NUT, PANEL MOUNT 5/8-24 X 3/32 BRASS
5	1	SP096	90703052	NUT, LEAD SCREW, 1/4-16 4 START
4	1	TW446	99090081	LENS, #1, V2, PYREX, AI
3	1	TW405	99090079	LENS #2, ME-AI
2	1	TWA037	80570039	BEARING ASSEMBLY, ZOOM, SLOTTED
1	1	TWA036	80570038	BEARING ASSEMBLY, ZOOM
ITEM NO.	QTY.	FILENAME	PART NO.	DESCRIPTION

BILL OF MATERIALS

UNLESS OTHERWISE SPECIFIED:	RELEASE DATE:	CE:	High End	2105 GRACY FARMS LANE	
DIMENSIONAL TOLERANCES:	ENG:	OA:		AUSTIN, TEXAS 78758	
0 PLACE DECIMAL = ±0.38	ME:	DRW:		(512) 836-2242	
1 PLACE DECIMAL = ±0.25	MEG:			FAK (512) 832-4128	
2 PLACE DECIMALS = ±0.13				http://www.highend.com	
ANGLES = ±0.5°					

FOR PAINTED PARTS REFER TO ENG. SPEC. MANUAL WI-0582	MATERIAL:	FINISH:	PART NO.	DRAWING NO.	REV.
ALL COMPONENTS, MATERIALS AND FINISHES TO BE R&HS COMPLIANT	CHARTED	N/A	80160065	TWA079_SVC	NA
MIN. DRAFT	INTERPRET DIMENSIONS PER ASME Y14.5M-1994	SI METRIC A1	DO NOT SCALE	SCALE: 1:250	SHEET: 1 OF 1
MIN. RADIUS	THIRD ANGLE PROJECTION				
FLATNESS	DIMENSIONS ARE IN MILLIMETERS				
THICKNESS					
VOLUME					

PROPRIETARY NOTICE: THIS DOCUMENT CONTAINS CONFIDENTIAL AND PROPRIETARY INFORMATION OF HIGH END SYSTEMS INC., (ALSO DBA LIGHTWAVE RESEARCH) AND IS GIVEN TO THE RECEIVER IN CONFIDENCE. THE RECEIVER ACCEPTS AND AGREES THAT, EXCEPT AS AUTHORIZED BY HIGH END SYSTEMS, THE RECEIVER WILL NOT PERMIT THE USE OF THE DOCUMENT OR ANY COPY THEREOF OR THE INFORMATION THEREIN, WILL NOT COPY OR PERMIT COPYING THE DOCUMENT OR THE INFORMATION THEREIN, AND WILL UPON COMPLETION OF THE NEED TO RETAIN THE DOCUMENT, OR UPON DEMAND, RETURN THE DOCUMENT WITHOUT RETAINING ANY OF THE INFORMATION CONTAINED THEREIN IN ANY FORM WHATSOEVER.